

GEWI® Steel High Yield Threadbar System

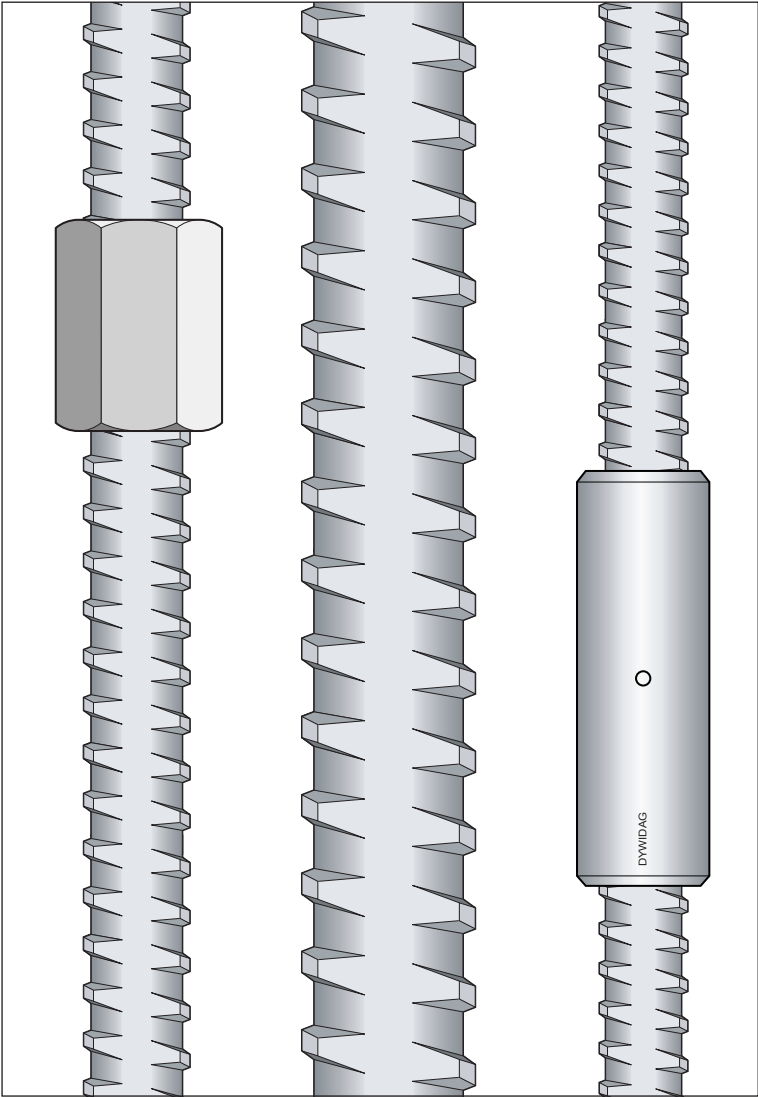

GEWI® Steel High Yield Threadbar System

GEWI® Steel High Yield Threadbar is a high tensile alloy steel bar which features a coarse left-hand thread over its full length. The system is proven worldwide and offers versatility in a range of applications.

Manufactured in accordance with the German Certificate of Approval (Deutsches Institut für Bautechnik), the system also offers general conformance with BS 4449 : 2005 (Steel for the Reinforcement of Concrete).

The minimum specified characteristic yield strength is 500 N/mm² for bar diameters 16 - 50mm and 555 N/mm² for the 63.5mm diameter bar. 16 - 50mm bars can be welded using appropriate industry practices relative to the carbon content of the steel. Welding of the higher grade 63.5mm diameter bar is also acceptable with additional measures.

Key features of the system are:

- Fully Threaded Bar - can be cut and coupled at any point.
- Robust Threadform - ideal for construction site use.
- Coarse Pitch Threadform (d/2, except Ø 63.5mm which is d/3) with two flats – ensures thread is self cleaning.
- Fully Galvanized Systems - galvanized threadbars and accessories also available from stock.

Technical Data for GEWI® Steel High Yield Threadbar

Nominal Diameter	Steel Grade	Ultimate Strength f _{pu}	Yield Strength	70% (b) Ultimate Strength	50% Ultimate Strength	Cross Sectional Area	Diameter Over Threads	Thread Pitch	Bar Weight
mm	N/mm ²	kN	kN	kN	kN	mm ²	mm	mm	kg/m
16	500/600	121	100	85	61	201	19	8	1.58
20	500/600	188	157	132	94	314	23	10	2.47
25	500/600	295	245	206	147	491	28	12.5	3.85
28	500/600	370	308	259	185	616	32	14	4.83
32	500/600	482	402	337	241	804	36	16	6.31
40	500/600	756	630	529	378	1260	45	20	9.87
50	500/600	1176	980	823	588	1960	56	26	15.40
63.5	555/700	2217	1758	1552	1108	3167	69	21	24.80

(a) Yield Stress, in general terms, equals 0.1% Proof Stress.

(b) For geotechnical applications 75% f_{pu} may be used for proof testing.

Modulus of Elasticity: E = 205,000 N/mm² +/- 5%.

Stock Lengths: All bar diameters 12.0m. Tolerances +/- 100mm. Special lengths up to 18.0m are available to order.

All bar diameters can be cut to length to suit customer requirements or supplied bent to BS 8666 : 2000.

Couplers for GEWI® Steel High Yield Threadbars

Couplers enable GEWI® Steel Threadbars to be coupled or extended, reliably and efficiently. It is important that the two threadbars meet centrally within the coupler, and remain so during installation, to ensure correct load transfer. Coupler strength = 1.3 x Yield Strength of the bar, which equates to 1.08 x Ultimate Strength, in accordance with German Approval Certificates.

With all types of coupler, precautions should be taken to ensure that the coupler remains centrally located during handling and installation. This can be achieved through the use of grub screws, a centre pin or lock nuts.

The choice of coupler type depends on the application. The static coupler is used either in constant tension or a combination of tension and compression loading, with the longer dynamic coupler used when vibration and cyclical load reversals are anticipated.



standard coupling

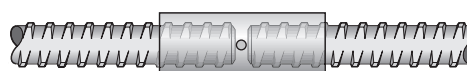

centre pin - optional



paint - visual indicator

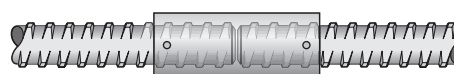

grub screws - optional

Lock nuts should be used at each end of the coupler when the threadbar is used in reinforced concrete applications designed in accordance with BS 8110. These lock nuts should be torqued to a predetermined value to prevent cracking of the structural concrete at the coupler when the joint comes under load. See table on Page 3 for torque values.

GEWI® Steel High Yield Threadbar Accessories

Nominal Diameter	Flat Plate Stock Size *	Hexagonal Nut		Recessed Plate Stock Size *	Domed Nut		Formed Plate Stock Size *	Hemisphere	
		AF	Length		AF	Length		Dia.	Length
mm	mm	mm	mm	mm	mm	mm	mm	mm	mm
16	150 x 150 x 10	32	40	150 x 150 x 20			150 x 150 x 10	46	18
20	150 x 150 x 10	36	45	150 x 150 x 20	35	41	150 x 150 x 10	46	18
25	150 x 150 x 10	41	50	150 x 150 x 20	38	45	150 x 150 x 10	57	23
28	150 x 150 x 10	46	55	150 x 150 x 20	43	54	150 x 150 x 10	57	23
32	200 x 200 x 30	55	60	200 x 200 x 30	46	57		80	33
40	200 x 200 x 40	65	70	200 x 200 x 40				120	55
50	300 x 300 x 50	80	85	300 x 300 x 50				120	60
63.5	300 x 300 x 50	100	115						



Nominal Diameter	Static Coupler ^(a)		Static Coupler ^(b)		Dynamic Coupler ^(a)		Lock Nut		Torque Value	Flanged Nut		
	Dia.	Length	Dia.	Length	Dia.	Length	AF	Length		AF	Length	Dia.
mm	mm	mm	mm	mm	mm	mm	mm	mm	Nm	mm	mm	mm
16	32	90	32	90	30	115	32	30	300	30	35	50
20	36	105	36	105	34	130	32	40	400	36	40	60
25	40	115	40	115	40	150	41	40	700	41	45	70
28	45	125	45	125	45	170	41	45	950	46	50	85
32	52	140	52	140	50(AF)	180	50	50	1500**	50	60	100
40	65	160	65	160	60(AF)	210	65	70	2900**	60	70	120
50	80	200	80	200	80(AF)	240	80	85	8000**	80	85	150
63.5	102	260	102	260	102	260	100	115	8000**	100	115	250

* Anchor plates can be supplied in any size to suit customer requirements.

** Torque applied to lock nut using hydraulic torque wrench.

(a) Machined coupler

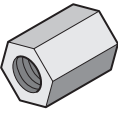
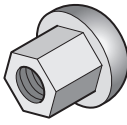
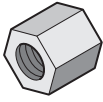
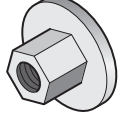
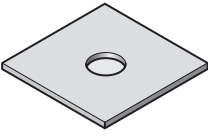
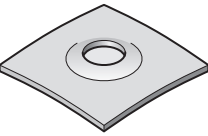
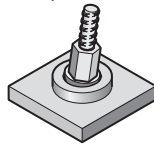
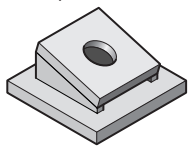
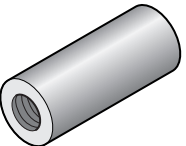
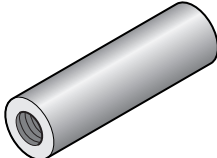
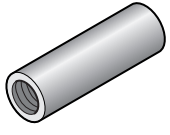
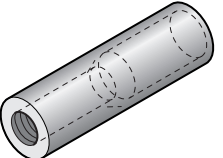
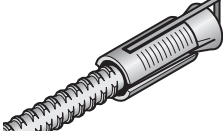
(b) Cast coupler.

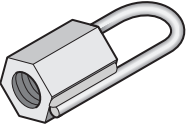
Nuts	Hexagonal Nut 	Domed Nut 	Lock Nut 	Flanged Nut 
Plates	Flat Plate 	Formed Plate up to 20° 	Articulating Plate up to 30° 	Gusseted Plate up to 45° 
Couplers	Static Coupler 	Dynamic Coupler 	Contact Coupler 	Transition Coupler 
Accessories	Mechanical Shell 	Tapered Washer up to 15° 	Hemisphere up to 30° 	Lifting Shackle 

Corrosion Protection

Galvanizing to BS EN ISO 1461 : 1999

Rock Bolts
Soil Nails
Temporary Ground Anchors

Double Corrosion Protection to BS 8081 : 1989

Permanent Soil Nails
Permanent Ground Anchors

Applications

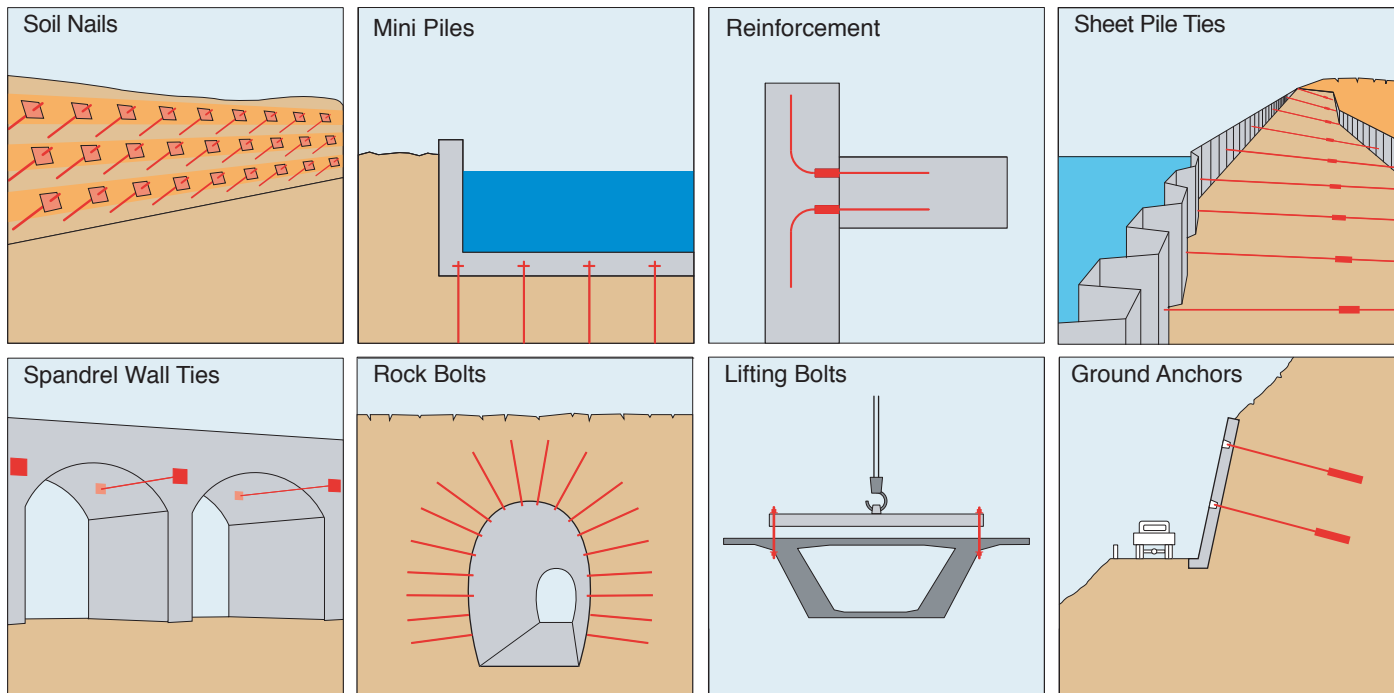

Stressing Equipment

Jack Selection Chart			Bar Diameter mm							
Capacity	Stroke	Weight	16	20	25	28	32	40	50	63.5
100kN	150mm	15kg	✓							
140kN	150mm	15kg	✓	✓	✓	✓	✓			
300kN	50mm	21kg	✓	✓	✓	✓				
300kN	150mm	36kg		✓	✓	✓				
600kN	50mm	37kg			✓	✓	✓	✓		
1100kN	50mm	46kg					✓	✓	✓	✓
1500kN	180mm	50kg							✓	✓
2000kN	250mm	180kg								✓

Stressing Dimensions

Nominal Diameter	Steel Grade	Dim. A	Dim. B
mm	N/mm ²	mm	mm
16	500/600	40	45
20	500/600	45	55
25	500/600	50	60
28	500/600	55	65
32	500/600	60	70
40	500/600	70	80
50	500/600	85	100
63.5	555/700	115	130

The diagram shows a cross-section of a threaded bar with a central nut and washer. Dimension A is the length of the bar, and dimension B is the length of the threaded section.

Dimension B is the minimum threadbar projection required for stressing.

DYWIDAG-SYSTEMS INTERNATIONAL LTD.

Northfield Road
Southam
Warwickshire
CV47 0FG

Telephone 01926 813980
Facsimile 01926 813817
E-mail sales@dywidag.co.uk
Web Site www.dywidag-systems.com/uk

Quality Assurance



DYWIDAG-Systems International
Certificate Number
FM 25723

